

DIY

Baby Doll's Crib

CRIB PLANS

www.lovecreatecelebrate.com



HEADBOARD

figure 1.0

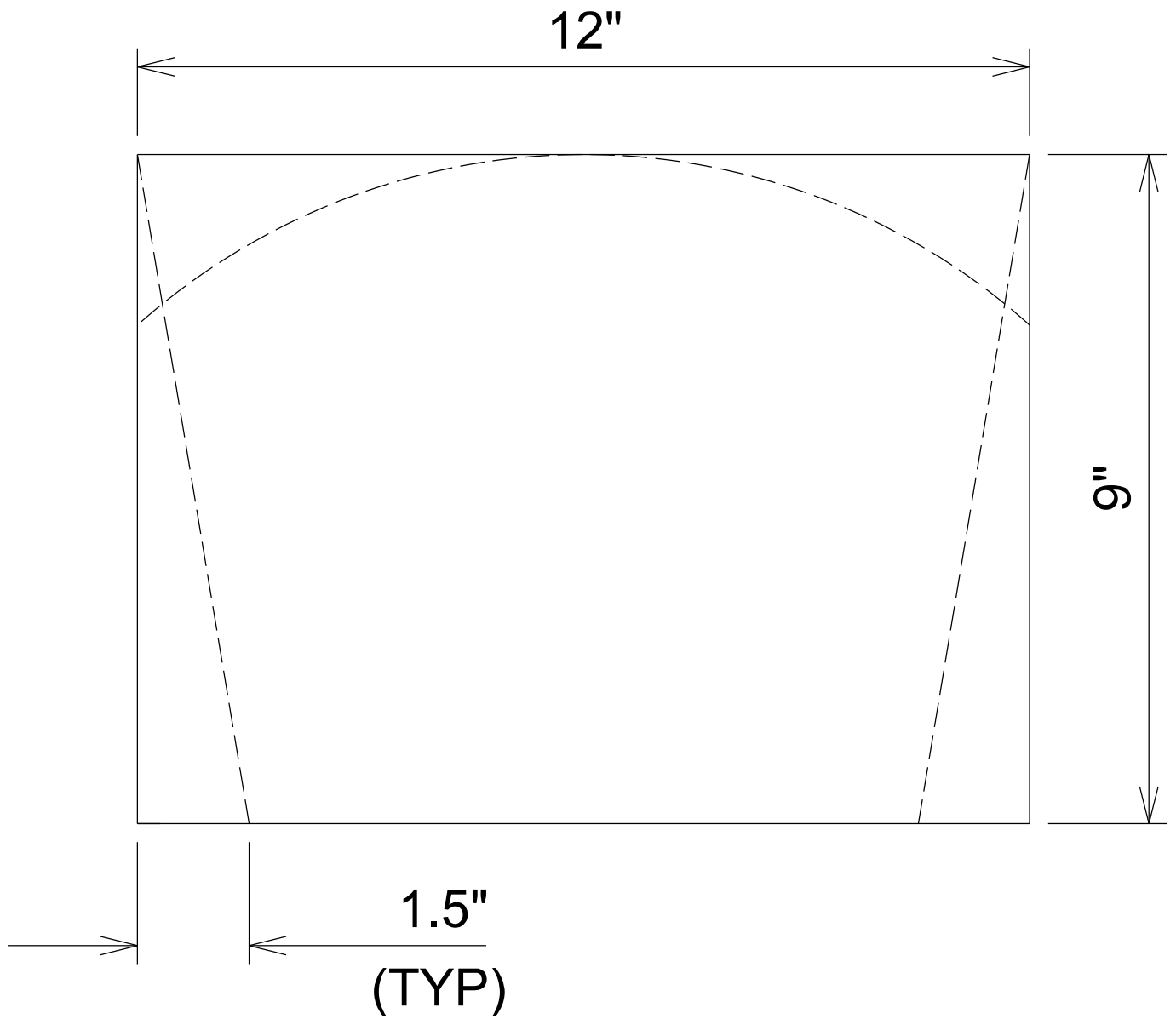

HEADBOARD

figure 1.1

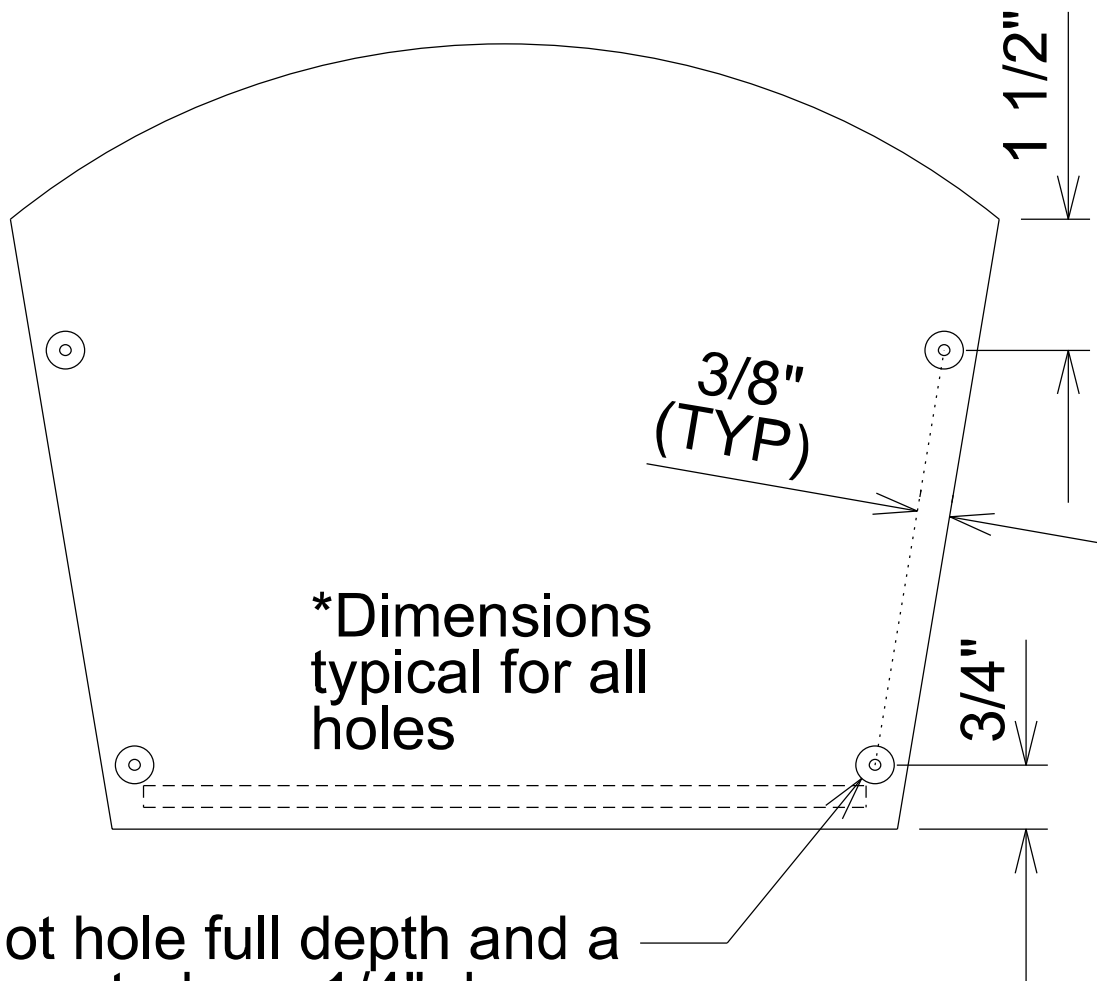

1/8" pilot hole full depth and a 7/16" counterbore 1/4" deep (TYP 4 holes)

HEADBOARD

figure 1.2

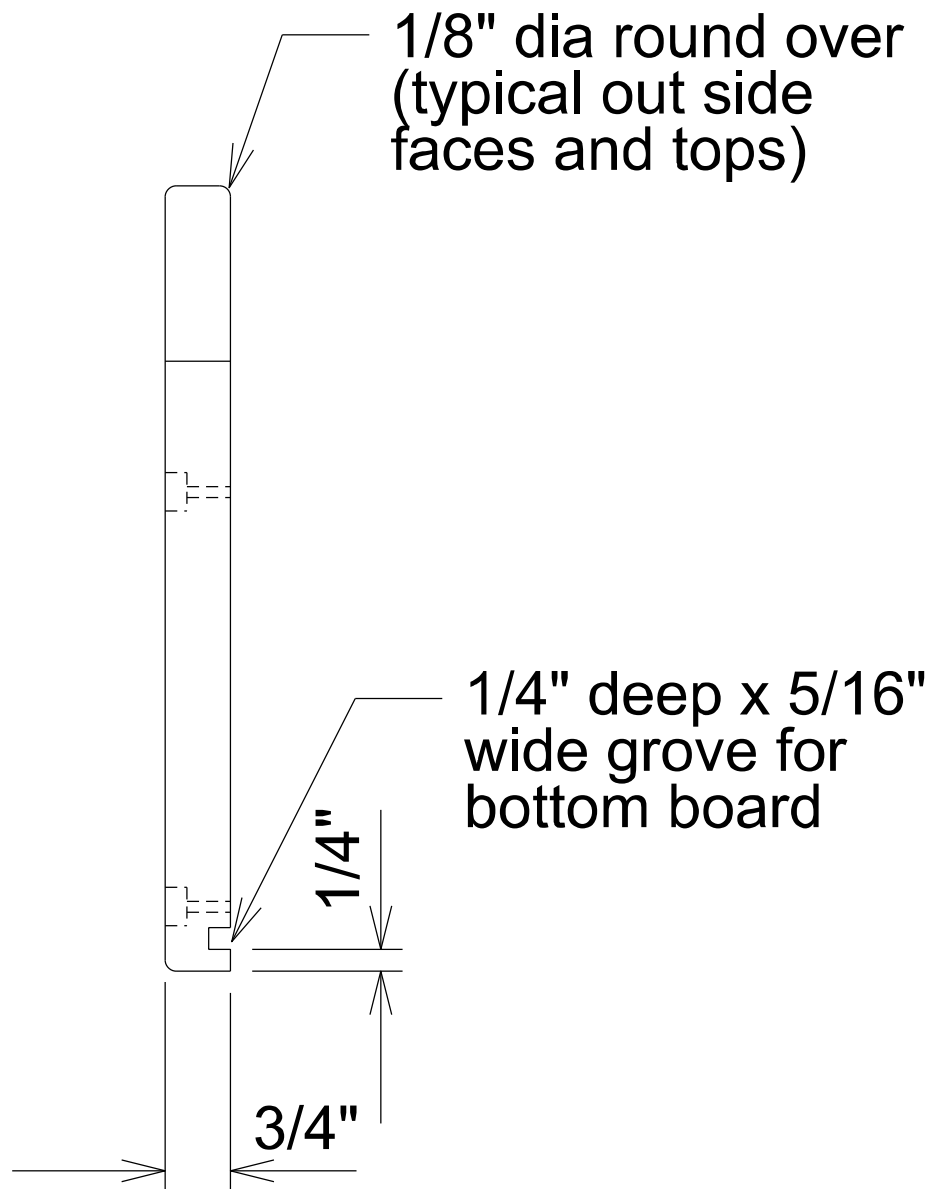

FOOT BOARD

figure 2.0

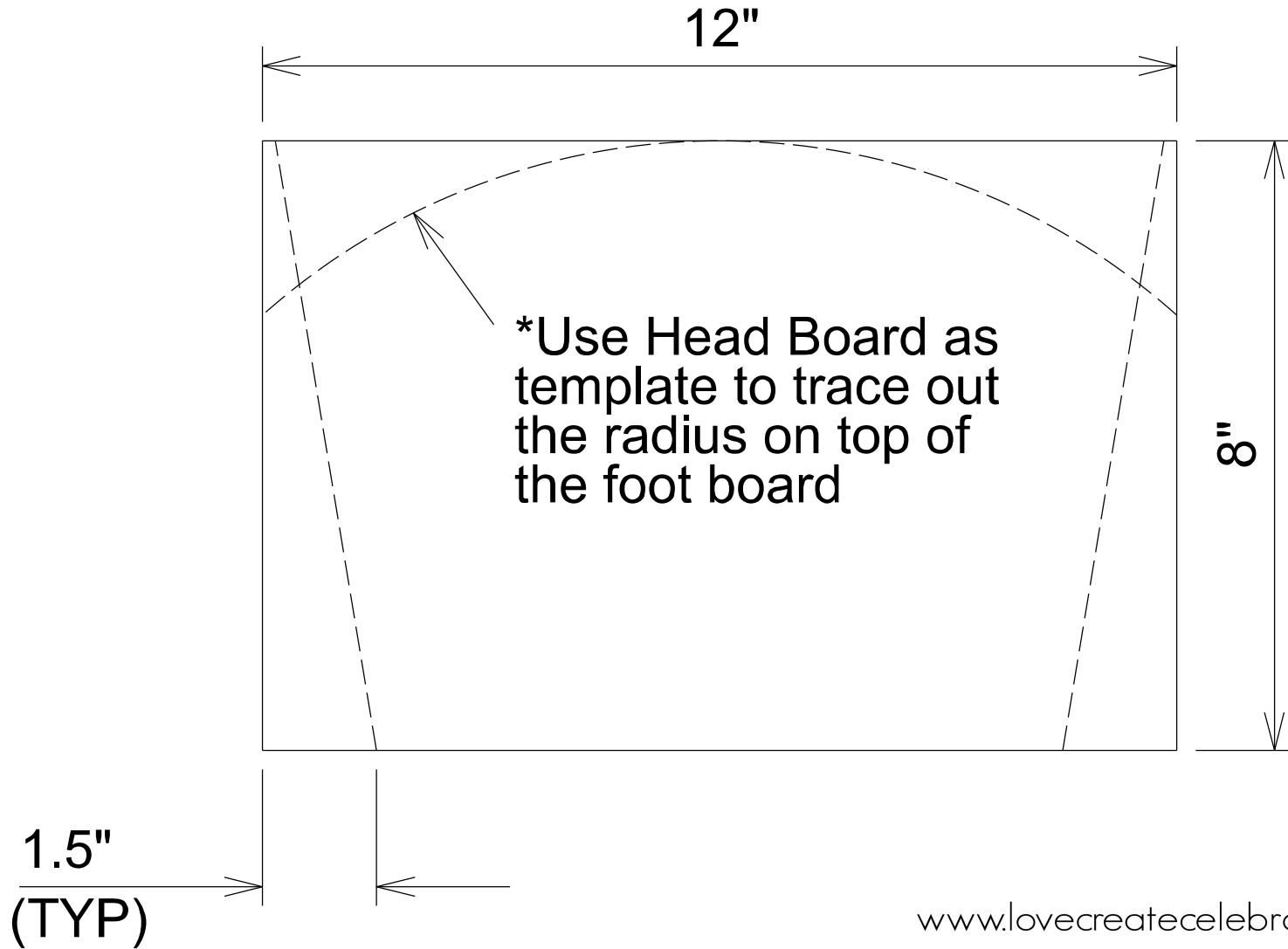

FOOT BOARD

figure 2.1

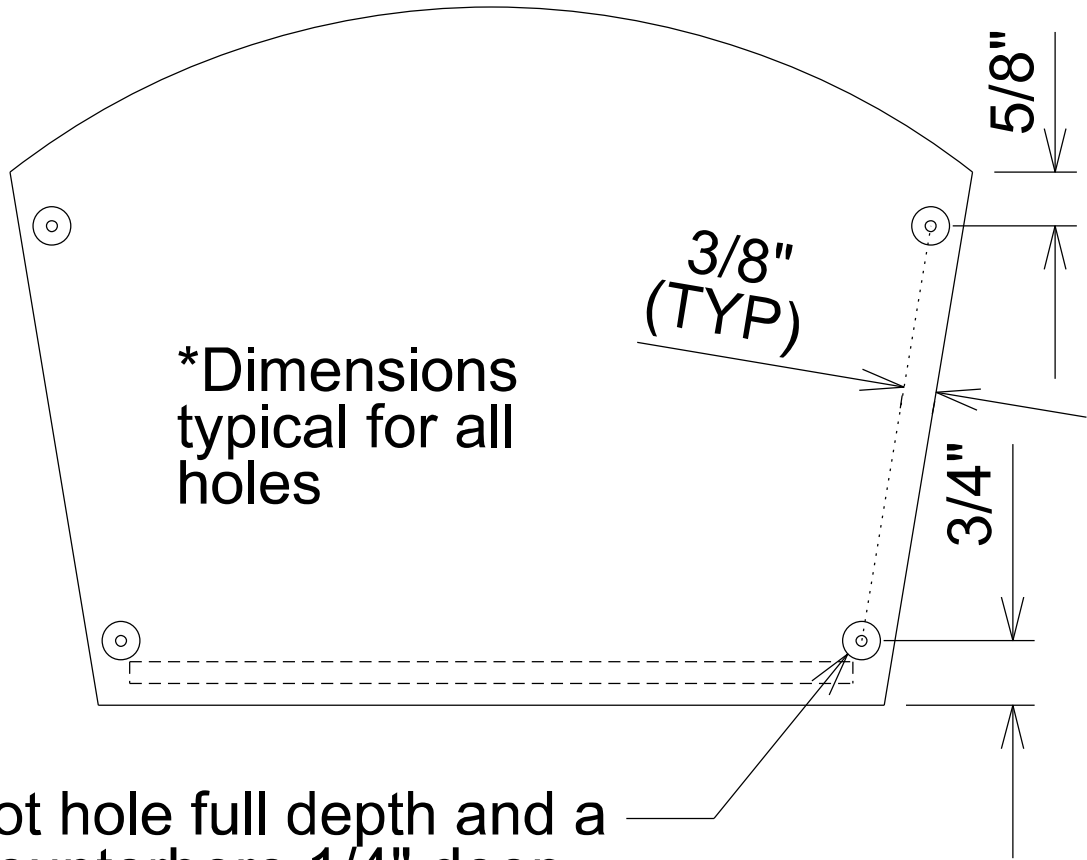

$1/8''$ pilot hole full depth and a $7/16''$ counterbore $1/4''$ deep (TYP 4 holes)

FOOT BOARD

figure 2.2

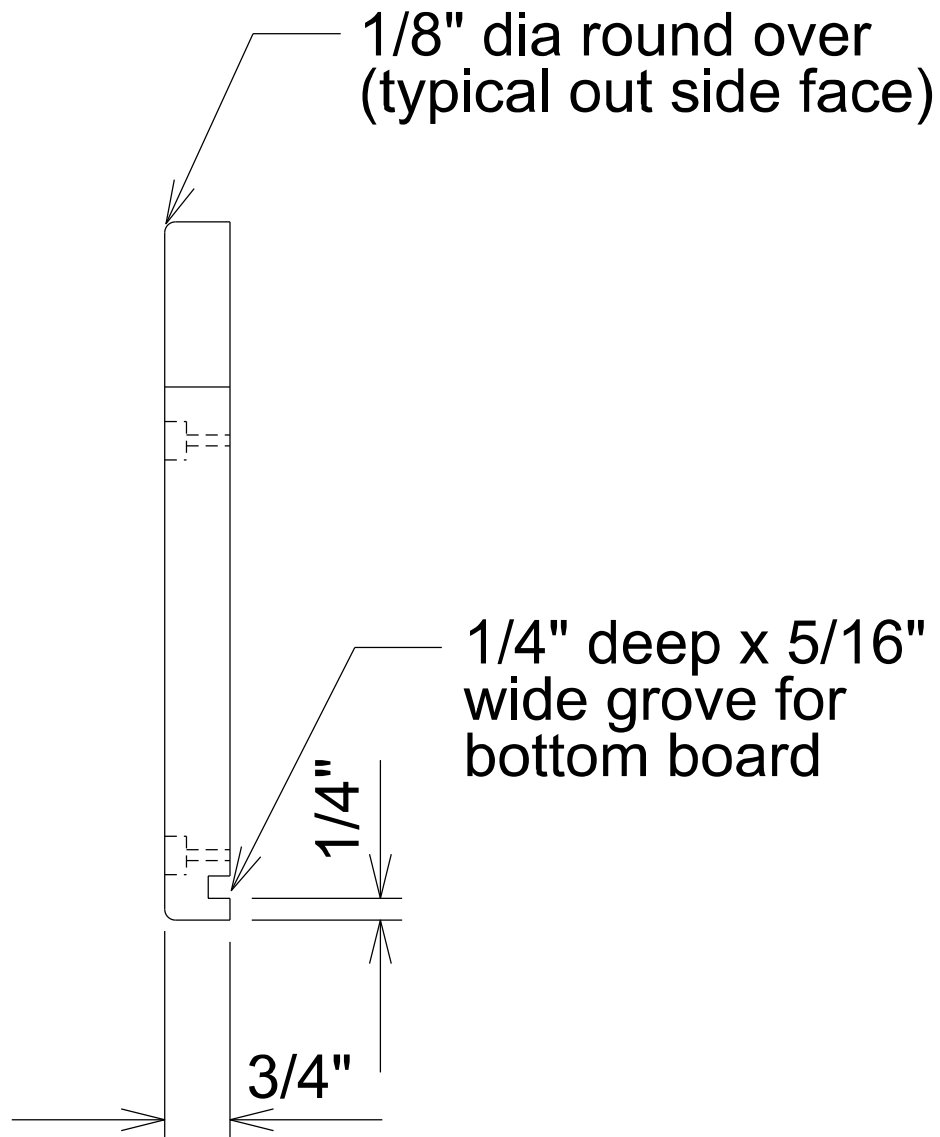

SIDE RAIL Figure 3.0

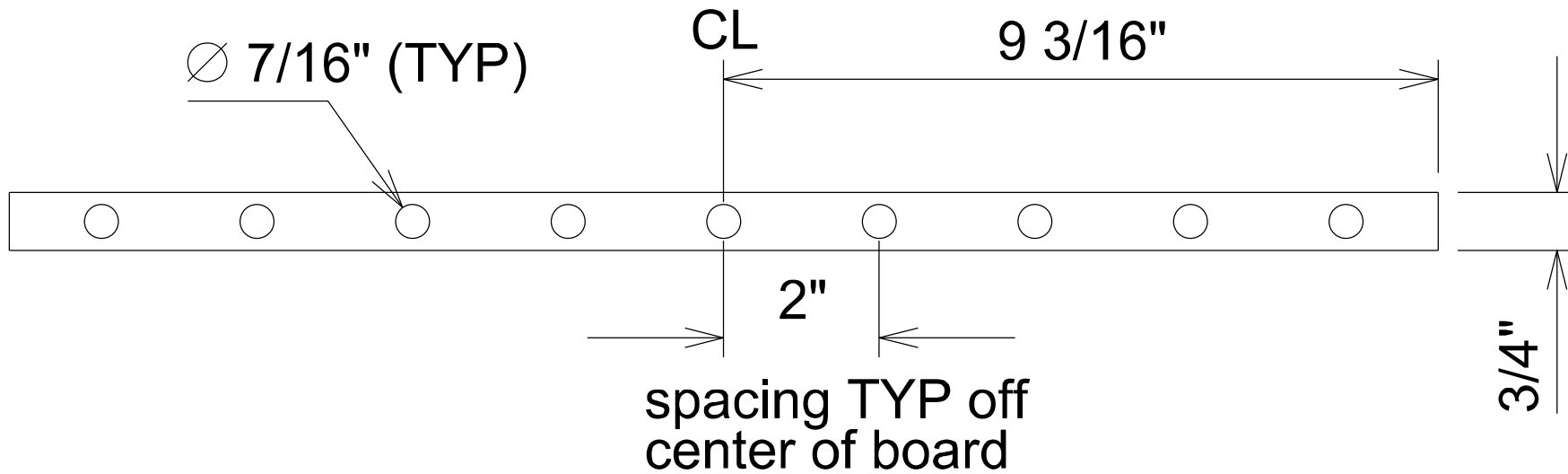

SIDE RAIL typical top and bottom Figure 3.1

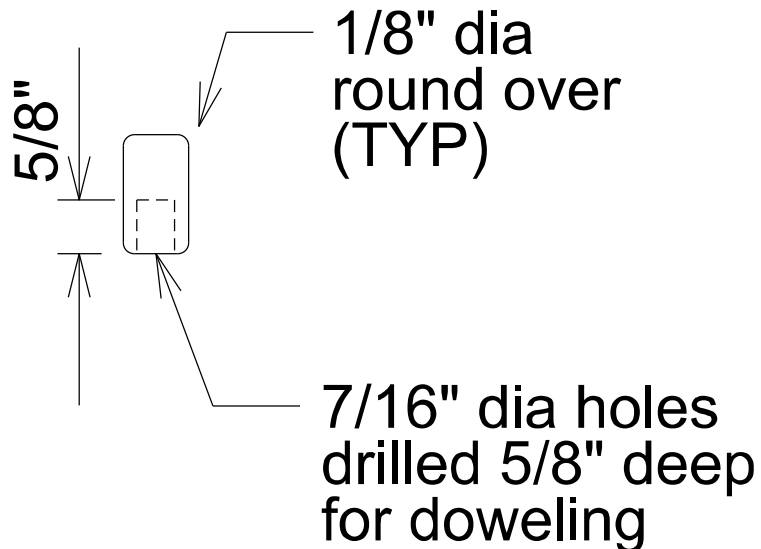

SIDE RAIL bottom only Figure 3.2

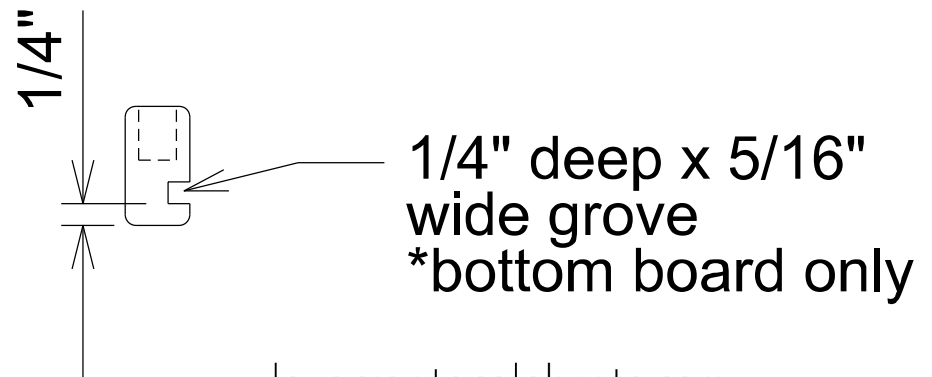

RAIL ASSEMBLY

Figure 4.0

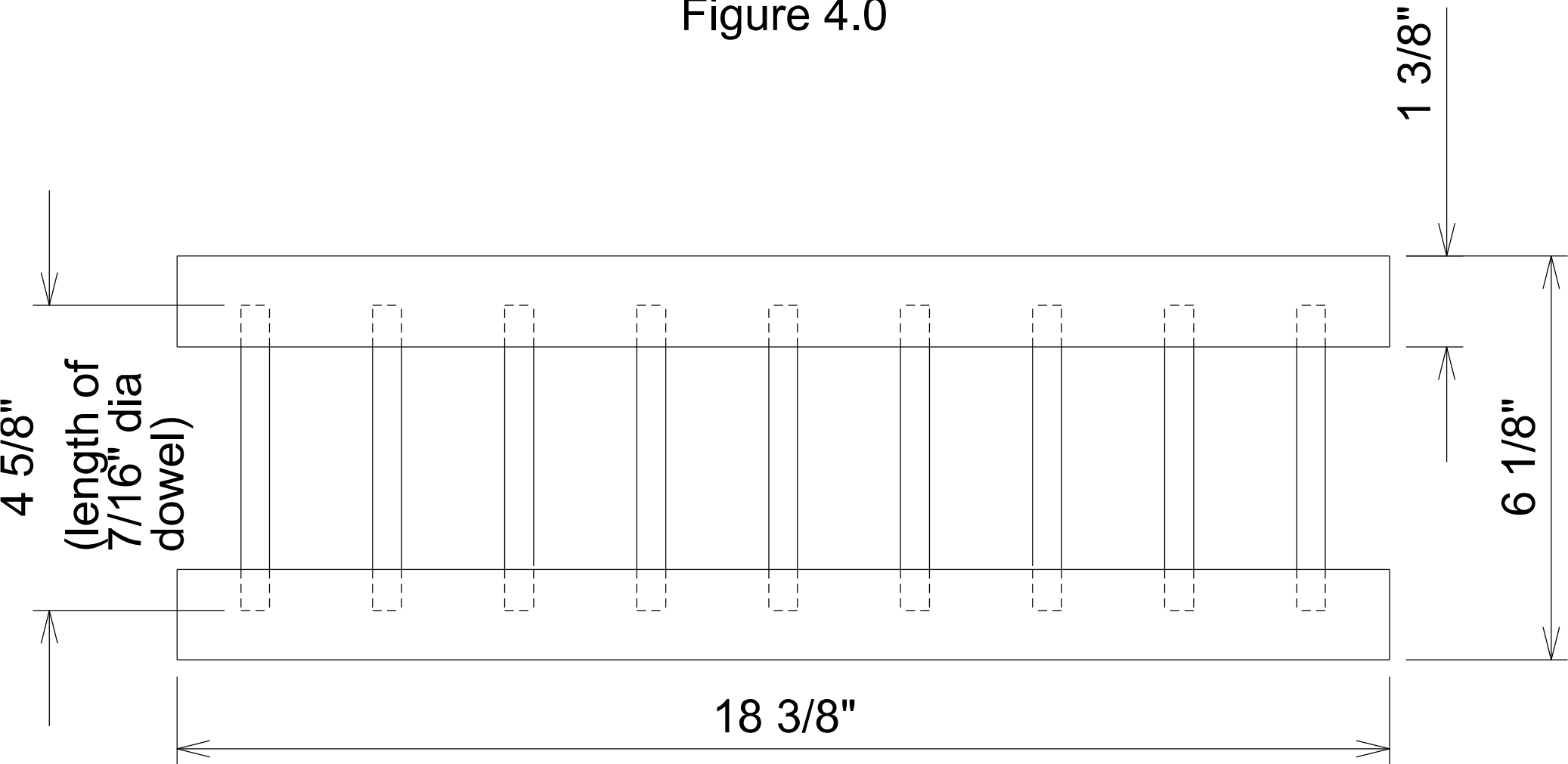

Rocker Figure 5.0

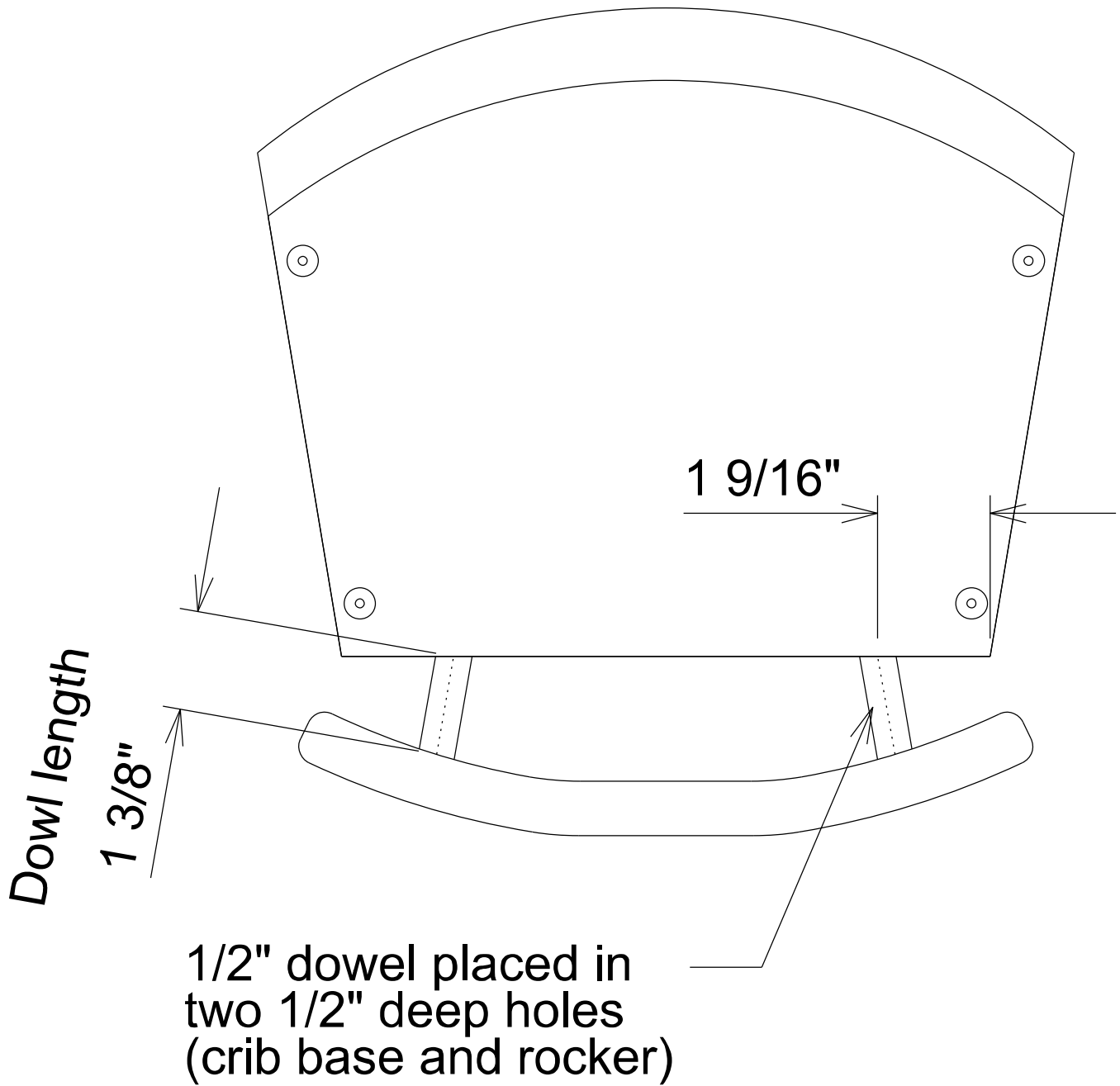

Rocker Figure 5.1

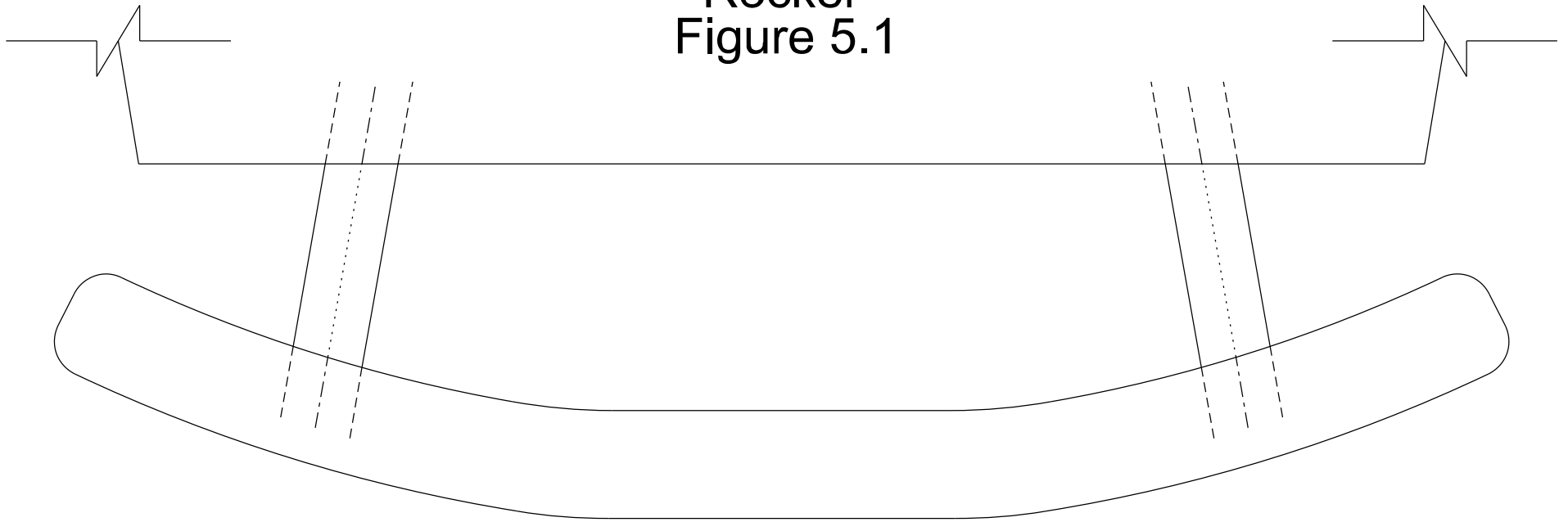

***Print at 1:1 to use as a template to sketch shape on wood for cut detail**

BOTTOM BOARD
Figure 6.0

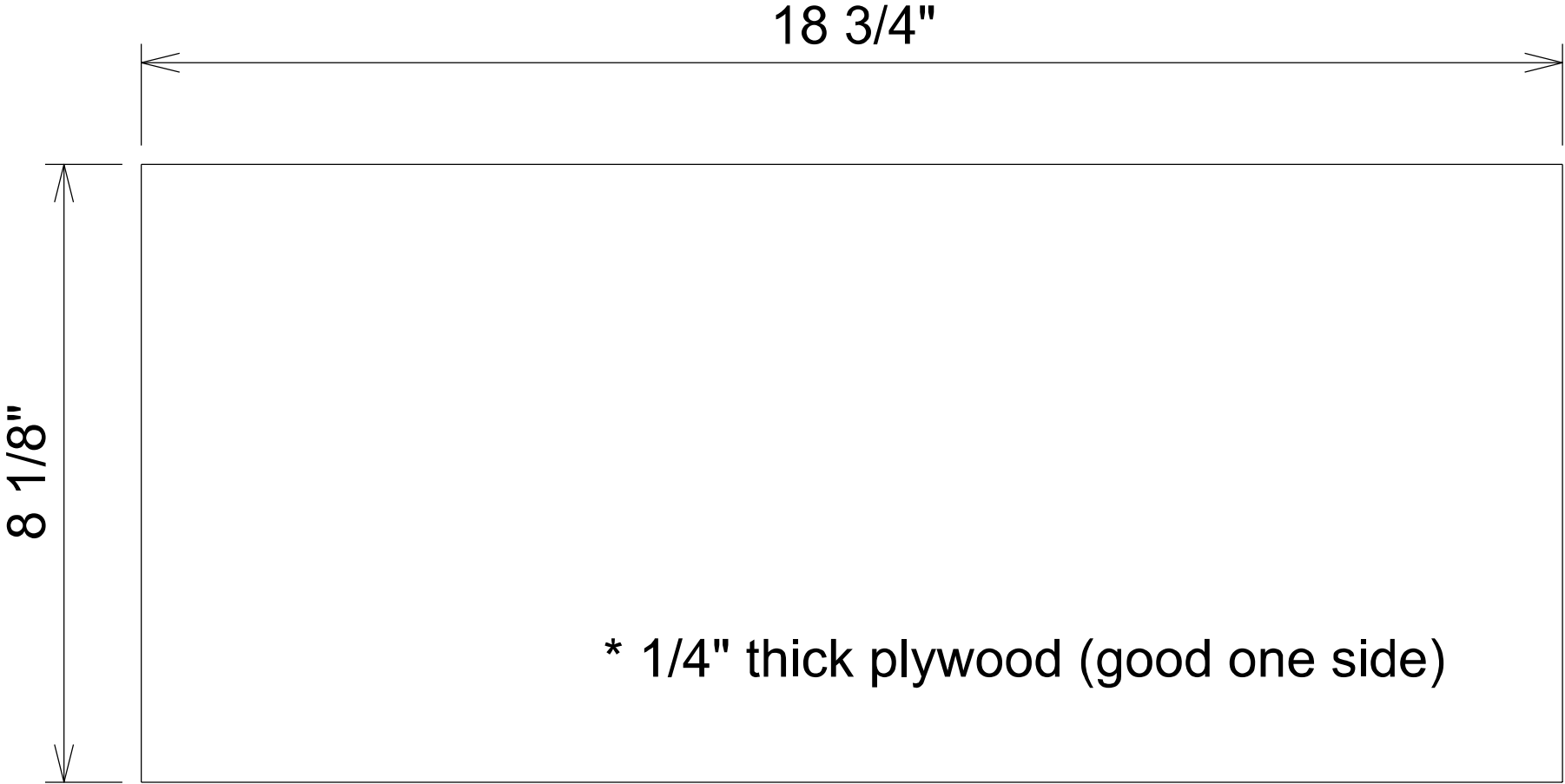

Final Assembly
Figure 7.0

